

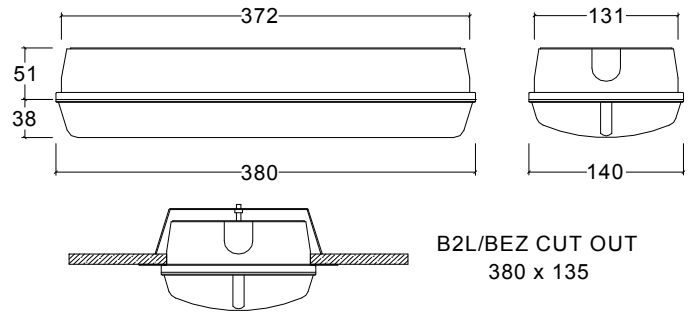

# Technical Specification Sheet for B2L Range of Luminaires



Dimensions (mm)

A modern 8 watt weatherproof Bulkhead Luminaire (rated IP65), suitable for most internal and external applications. Available in Maintained, Non-Maintained Slave and Mains versions. Supplied as standard with a high light transmission Fresnel diffuser.

| Product Specification |  |       |        |            |      |        |                             |         |          |          |      |  |
|-----------------------|--|-------|--------|------------|------|--------|-----------------------------|---------|----------|----------|------|--|
| Data                  | Self Contained Luminaire<br>B2L/8/***                        |       |        |            |      |        | Slave Luminaire<br>B2L/**** |         |          |          |      |  |
|                       | M3   | M3/SP | NM3    | NM3/SP     | ST   | NM3/3C | M3/3C                       | 24      | 50       | 110      | 230  |  |
| Input Voltage         | 230 Volt AC +/- 10% 50 Hz                                    |       |        |            |      |        | 24 Volt                     | 50 Volt | 110 Volt | 230 Volt |      |  |
| Power Rating          | 12VA   |       | 8VA    |            | 21VA | 8VA    | 25VA                        | 8.9VA   | 7.5VA    | 7.7VA    | 13VA |  |
| Light Source          | 1 x 8 Watt 300mm Coolwhite Fluorescent Tube (2 for Model ST) |       |        |            |      |        |                             |         |          |          |      |  |
| Light Output          | 105 Lumens   |       |        | 180 Lumens |      |        | 275 Lumens                  |         |          |          |      |  |
| Emergency Duration    | 3 Hours  |       |        |            |      |        | Not Applicable              |         |          |          |      |  |
| Battery Type          | 4Ah Nickle Cadmium 2.4v                                      |       |        | 3.6v       |      |        |                             |         |          |          |      |  |
| Charger               | 250mA with LED Indicator                                     |       |        |            |      |        |                             |         |          |          |      |  |
| Recharge Time         | 24 Hours (14 Hours for 1 Hour Duration)                      |       |        |            |      |        |                             |         |          |          |      |  |
| Auto Test             | Yes  |       |        | No         |      |        |                             |         |          |          |      |  |
| Legend Kit            | B1L/LG   |       |        |            |      |        |                             |         |          |          |      |  |
| Recessing Kit         | B2L/BEZ  |       |        |            |      |        |                             |         |          |          |      |  |
| Dimensions            | 372mm x 140mm x 89mm   |       |        |            |      |        |                             |         |          |          |      |  |
| Weight                | 1.6Kgs   |       | 1.4Kgs |            |      | 1.7Kg  |                             | 1.1Kgs  |          |          |      |  |

| Product Reference         | Mounting Height | Transverse to Wall |     |     | Transverse Spacing |     |     | Axial to Wall |     |     | Axial Spacing |     |     |
|---------------------------|-----------------|--------------------|-----|-----|--------------------|-----|-----|---------------|-----|-----|---------------|-----|-----|
|                           |                 | 0.2                | 0.5 | 1.0 | 0.2                | 0.5 | 1.0 | 0.2           | 0.5 | 1.0 | 0.2           | 0.5 | 1.0 |
| B2L/8/NM3<br>B2L/8/NM3/SG | 2.5             | 3.8                | 1.8 | 1.5 | 10.0               | 5.5 | 5.0 | 3.0           | 1.8 | 1.0 | 8.0           | 5.5 | 4.0 |
|                           | 4.0             | 4.0                | 1.3 | n/a | 10.5               | 5.0 | 3.5 | 2.8           | 1.3 | n/a | 9.0           | 5.0 | n/a |
|                           | 6.0             | 3.1                | n/a | n/a | 10.6               | n/a | n/a | 2.8           | n/a | n/a | 9.0           | n/a | n/a |
| B2L/8/M3<br>B2L/8/M3/SG   | 2.5             | 3.4                | 1.6 | 1.4 | 9.0                | 5.0 | 4.5 | 2.7           | 1.6 | 0.9 | 7.2           | 5.0 | 3.6 |
|                           | 4.0             | 3.6                | 1.2 | n/a | 9.5                | 4.5 | 3.2 | 2.5           | 1.2 | n/a | 8.1           | 4.5 | n/a |
|                           | 6.0             | 2.8                | n/a | n/a | 9.5                | n/a | n/a | 2.5           | n/a | n/a | 8.1           | n/a | n/a |

BLE holds ISO 9000 accreditation for the appropriate categories of emergency lighting supplied by the Company. All luminaires that BLE supplies to the European Market are designed to comply with all of the requirements of BS EN 60598-2-22.

| Recommended Routine Inspection |  |
|--------------------------------|--|
| <b>Daily</b>                   | Check the LED is illuminated. If lamp shows any sign of blackening then replace.         |
| <b>Monthly</b>                 | Check that the Luminaire operates in the emergency mode for up to 15 minutes.            |
| <b>6 Monthly</b>               | Check that the Luminaire operates in the emergency mode for 1/3 of its rated duration.   |
| <b>Yearly</b>                  | Check that the Luminaire operates in the emergency mode for its full rated duration      |
| <b>General</b>                 | If the Luminaire fails the required duration replace the battery with an identical type. |